

Figure 1 - Floor Stud Hole Pattern

1		2	3/8-16X1.00 
3		4	3/8 
5		6	3/8 

**WARNING**

To avoid electric shock, do not energize any circuits before all internal and external electrical and mechanical clearances are checked to assure that all assembled equipment functions safely and properly.

**INSTALLATION INSTRUCTION:**

1. Check the depth of the floor stand ("C" dimension) to verify it matches the enclosure depth dimension.
2. Anchor six 3/8-inch diameter studs (not provided with kit) securely in the floor as shown in Figure 1.
3. Drill the appropriate hole pattern in the bottom of the enclosure as shown in Figure 2.
4. Bolt the floor stand to the enclosure as shown in Figure 3 using the 3/8-16x1.00 hex head screws (Item 2), washers (Items 3 and 4), and nuts (Item 5) provided. Firmly tighten all fasteners.
5. Position the enclosure and attached floor stands over the anchored floor studs, extending the studs through the base holes in the floor stands.
6. Secure the floor stands to the anchored floor studs with 3/8 inch nuts (Item 5) and lockwashers (Items 3 and 4) or with 3/8 inch locknuts and washers (not provided with kit). Torque to 120 in-lbs.

This accessory maintains UL/CSA Type 12, 4, 4X when installed per these instructions.

This accessory is covered by UL file E61997 and CSA file LR42186.

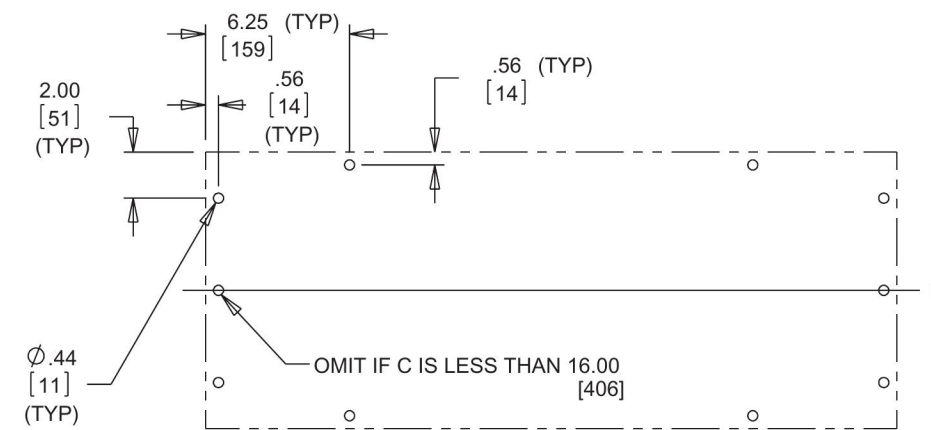

Figure 2 - Enclosure Bottom Hole Pattern

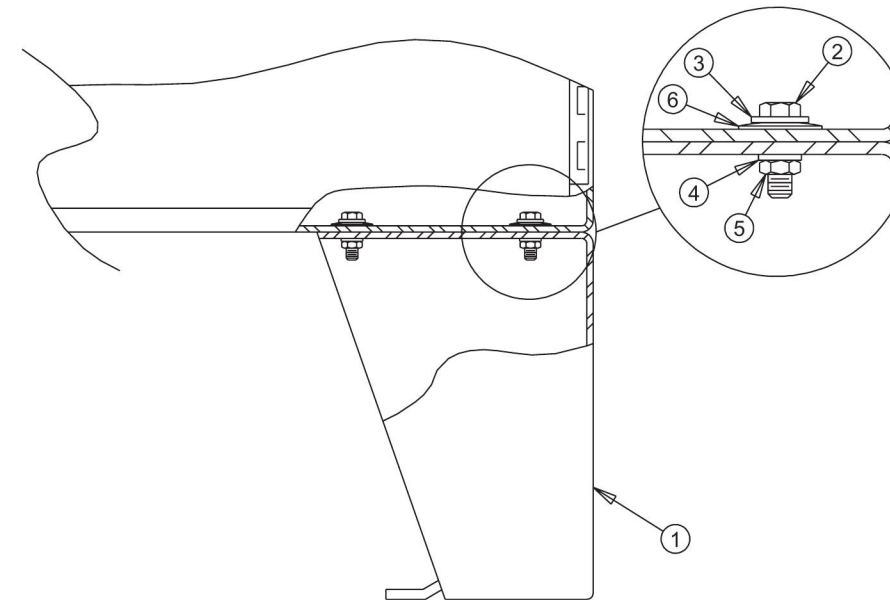

Figure 3

Catalog Number	Dim. C
AFK0608	8.06
AFK1208	
AFK1208SS	
AFK1808	
AFK2408	
AFK0610	
AFK1210	
AFL1210SS	
AFK1810	
AFK2410	
AFK2410SS	12.06
AFK0612	
AFK1212	
AFK1212SS	
AFK1812	
AFK2412	
AFK2412SS	
AFK1216	
AFK1216SS	
AFK1816	
AFK2416	20.06
AFK1220	
AFK0618	
AFK1218	
AFK1218SS	
AFK1224SS	